

Series 035 Product Overview

Features:

- Available with threaded body, or lower flange mounting
- Low profile for confined spaces
- Double locked arm attachment is bolted to piston rod and clamped around shaft diameter

Applications:

- Assembly
- Welding
- Light machining

Also Available:

See page 10.35 for clamping arms
See page 10.36 for jam nuts

Series 035-1



Threaded body design for mounting through fixture plates.

Series 035-2

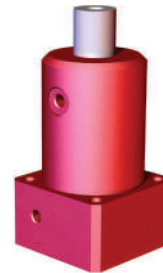

Flanged body design for quick and easy mounting

Series 035 Technical Information

Model	Swing Direction	Total Stroke [in]mm S	Stroke During Rotation [in]mm S1	Vertical Clamp Stroke [in]mm S2	Clamping Force [lbf.]N†	Bore Size [in]mm	Air Consumption‡ [ft³]dm³	Weight [lb.]kg	Replacement Seal Kit
035-125-190	RH	[1.04]	[0.51]	[0.53]	[20]	[0.98]	[0.005]	[0.56]	905516
035-125-290	LH	26,3	12,8	13,5	89	25	0,13	0,25	
035-132-190	RH	[1.13]	[0.56]	[0.57]	[30]	[1.26]	[0.008]	[0.94]	905517
035-132-290	LH	28,8	14,3	14,5	133	32	0,24	0,43	
035-140-190	RH	[1.20]	[0.57]	[0.63]	[60]	[1.57]	[0.015]	[1.31]	905518
035-140-290	LH	30,4	14,4	16	267	40	0,41	0,59	
035-150-190	RH	[1.18]	[0.63]	[0.55]	[69]	[1.97]	[0.023]	[1.81]	905519
035-150-290	LH	30	16	14	307	50	0,64	0,82	
035-225-190	RH	[1.05]	[0.54]	[0.51]	[20]	[0.98]	[0.005]	[0.56]	905516
035-225-290	LH	26,7	13,7	13	89	25	0,13	0,25	
035-232-190	RH	[1.06]	[0.57]	[0.49]	[30]	[1.26]	[0.008]	[1.13]	905517
035-232-290	LH	26,8	14,4	12,4	133	32	0,24	0,51	
035-240-190	RH	[1.09]	[0.57]	[0.52]	[60]	[1.57]	[0.015]	[1.40]	905518
035-240-290	LH	27,7	14,4	13,3	267	40	0,41	0,64	
035-250-190	RH	[1.13]	[0.63]	[0.51]	[69]	[1.97]	[0.023]	[1.90]	905519
035-250-290	LH	28,8	16	12,8	307	50	0,64	0,86	

† with standard clamping arm at 5bar[72psi]. ‡ per double stroke at 5bar[72psi]

Operating Pressure Range: 3bar[40psig] to 7bar[100psig]
Maximum Operating Temperature: 80°C[176°F]

Series 035 Standard Clamp Dimensions



Series 035-1

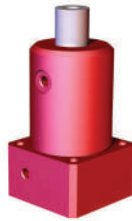
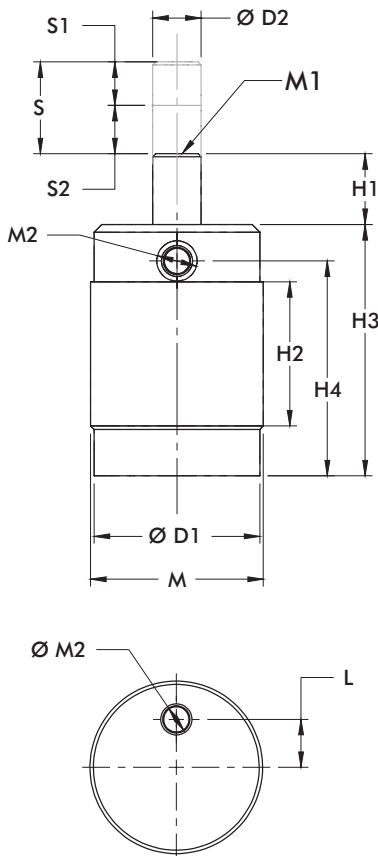

Series 035-2

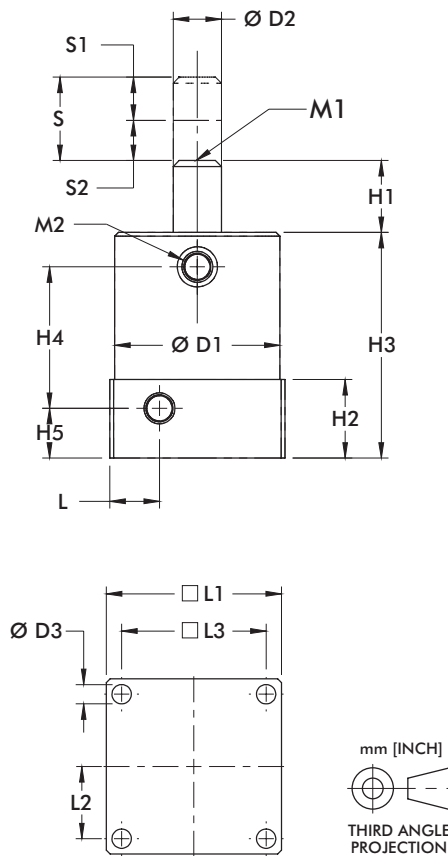

mm [INCH]
THIRD ANGLE PROJECTION

Mounting Options

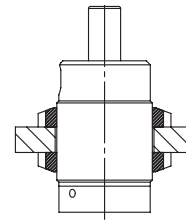

035-1
Threaded body mounts through a clearance hole and locked in place using two optional jam nuts

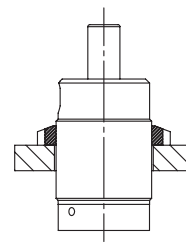

035-1
Threaded body mounts into a threaded hole and is locked in place using one optional jam nuts

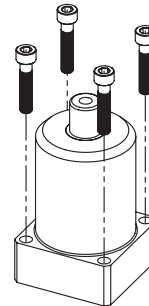

035-2
Mount using four mounting holes in the base flange

Model	ØD1	ØD2	D3	H1	H2	H3	H4	H5	L	L1	L3	M	M1	M2
035-125-()	[1.42] 36	[.55] 14	--	[0.57] 14,4	[1.50] 38,1	[2.76] 70	[2.25] 57,2	--	[0.35] 9	--	--	1-1/2 -16	1/4-20	#10-32
035-132-()	[1.79] 45,4	[.63] 16	--	[0.75] 19,1	[1.72] 43,7	[3.87] 98,2	[2.63] 66,7	--	[0.45] 11,4	--	--	1-7/8-16	5/16-18	1/8 NPT
035-140-()	[2.16] 54,8	--	--	[0.76] 19,4	[1.88] 47,7	[3.28] 83,2	[2.80] 71	--	[0.70] 17,8	--	--	2-1/4-16		
035-150-()	[2.36] 60	[0.79] 20	--	[0.70] 17,8	[2.00] 50,8	[3.48] 88,3	[2.95] 75	--	[0.50] 12,7	--	--	2-1/2-16	3/8-16	
035-225-()	[1.38] 35	[.55] 14	[.18] 4,5	[0.60] 15,2	[.91] 23	[2.62] 66,5	[1.60] 40,6	[0.50] 12,7	[0.57] 14,5	[1.57] 40	[1.22] 31	--	1/4-20	#10-32
035-232-()	[1.97] 50	[.63] 16	[.26] 6,5	[0.85] 21,6		[2.79] 71	[1.76] 44,6	[0.57] 14,5	[0.65] 16,5	[2.13] 54	[1.73] 44	--	5/16-18	1/8 NPT
035-240-()	[2.16] 54,8	--	--	[0.94] 23,9	[1.03] 26,1	[2.95] 75	[1.85] 47	[0.65] 16,5	[0.65] 16,5	[2.29] 58,2	[1.89] 48	--		
035-250-()	[2.36] 60	[0.79] 20	[.33] 8,5	[0.78] 19,7	[1.03] 26	[3.15] 80	[2.05] 52			[2.68] 68	[2.17] 55	--	3/8-16	

Series 035 Clamping Forces

Series 035 Clamping Force (w/ standard clamping arm)

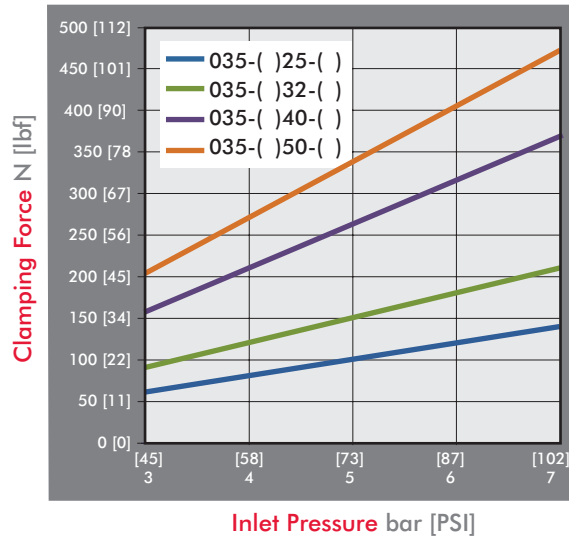

Series 035 Guidelines

DE-STA-CO Pneumatic Swing Clamps are designed for long life when using standard clamping arms and spindles. In the event that a longer arm or additional weight is needed, please consult these charts for the allowable weight and length.

Example: 035-132-190

At a weight of 80 gr, the maximum length of the arm is approximately 90mm.

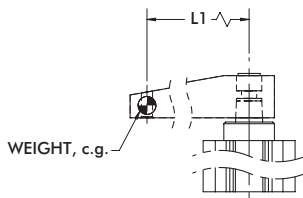

All data refers to an operating pressure of 5 bar (72psi) and an opening and closing time of 1 second.

25mm, 32mm Clamp Arm Weight

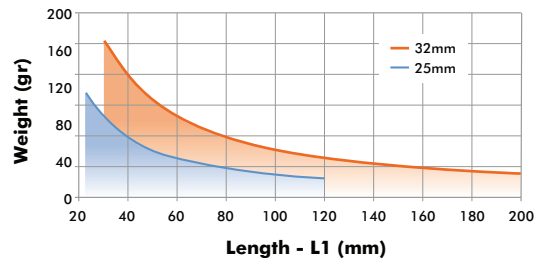

40mm, 50mm Clamp Arm Weight

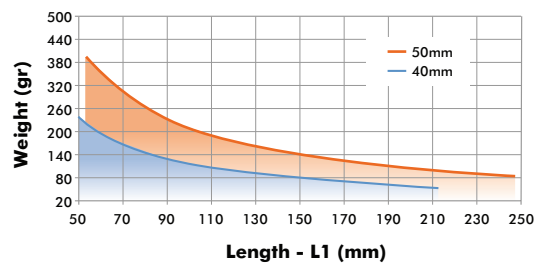

Series 035 Clamping Arm

Features:

- For standard use
- Aluminum construction
- Clamp on style connection for 360 deg. arm positioning

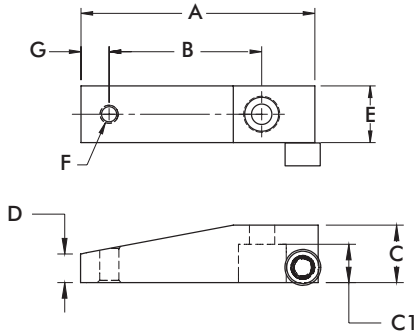

Part Number	Used with Model/series	A	B	C	C1	D	E	F	G	Weight [lbs] kg
036-551-01	035-12.... 035-22....	[2.38] 60.5	[1.36] 34.5	[0.63] 15.9	[0.40] 10.2	[0.31] 8.0	[0.75] 19.1	1/4-20	[0.32] 8.0	[0.10] 0.05
036-551-02	035-12.... 035-22....	[3.38] 85.9	[2.36] 60.0	[0.63] 15.9	[0.40] 10.2	[0.31] 8.0	[0.75] 19.1	1/4-20	[0.32] 8.0	[0.13] 0.06
036-630-01	035-13.... 035-23.... 035-14.... 035-24....	[3.10] 78.7	[2.00] 50.8	[0.75] 19.1	[0.50] 12.7	[0.38] 9.5	[0.75] 19.1	5/16-18	[0.38] 9.5	[0.15] 0.07
036-630-02	035-13.... 035-23.... 035-14.... 035-24....	[4.73] 120.0	[3.63] 92.1	[0.75] 19.1	[0.50] 12.7	[0.38] 9.5	[0.75] 19.1	5/16-18	[0.38] 9.5	[0.21] 0.10
036-787-01	035-15.... 035-25....	[4.00] 101.6	[2.75] 69.9	[1.00] 25.4	[0.70] 17.8	[0.50] 12.7	[1.00] 25.4	3/8-16	[0.38] 9.5	[0.33] 0.15
036-787-02	035-15.... 035-25....	[6.36] 161.5	[5.00] 127.0	[1.00] 25.4	[0.70] 17.8	[0.50] 12.7	[1.00] 25.4	3/8-16	[0.38] 9.5	[0.49] 0.22

Features:

- For use with Threaded Body Pneumatic Swing Clamps
- Variable height adjustment
- For recessed mounting
- Steel construction

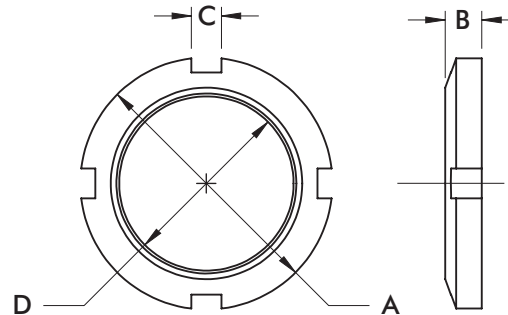

Part Number	Used with Model/series	A	B	C	D	Weight [lbs] kg
051-150-160	035-125-190 035-125-290	[2.00] 50.8	[0.38] 9.7	[0.275] 7.0	1 1/2-16 UN	[0.13] 0.06
051-187-160	035-132-190 035-132-290	[2.63] 66.7	[0.38] 9.7	[0.312] 7.9	1 7/8-16 UN	[0.25] 0.11
051-225-160	035-140-190 035-140-290	[3.00] 76.2	[0.50] 12.7	[0.312] 7.9	2 1/4-16 UN	[0.40] 0.18
051-250-160	035-150-190 035-150-290	[3.25] 82.6	[0.50] 12.7	[0.312] 7.9	2 1/2-16 UN	[0.44] 0.20